

STANDARD CONSTRUCTION

FRAME: .081" thk. (nominal) extruded aluminum, 6063-T52/T6 alloy. Channel type.

BLADE: .081" thk. (nominal) extruded aluminum 6063-T52/T6 alloy. Blades are approximately 4" on centers.

LOUVER FACE: Full width sill with drain head and non-drain blades contained within drain jambs.

SHAFT: .50" dia aluminum "Pin-Lock" rod.

BEARINGS: Celcon bearing material so that there will be no metal to metal friction.

LINKAGE: Extruded aluminum, concealed in the channel out of the airstream. The pivots, which rotate in Celcon bearings, are .50" dia. plated and machined steel. The pivot is locked to the 5/16" dia. aluminum linkage rod by a 1/4 - 20 set screw with epoxy locking patch.

SEALS: Extruded silicone rubber seals at blade edge. Polyurethane at jambs.

SCREEN: (When indicated, in a removable frame)
1/2" flattened aluminum, .051" thk,

-or- Insect screen 19/16 aluminum mesh, .011" dia,

-or- 1/2" sq. mesh intermediate double crimped aluminum wire, .063" dia.

FINISH: Mill.

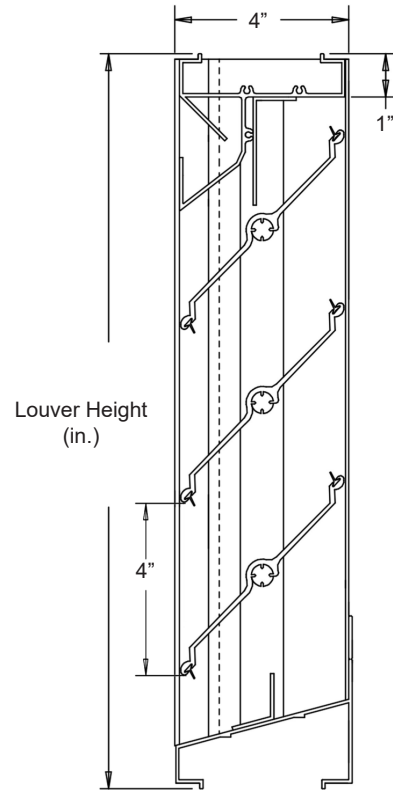

OPTIONS

Finishes - Enamels, Epoxies, etc.

Other screens also available.

Actuators - Electric, Pneumatic, Manual, etc.

NOTES

1. Nominal deductions will be made to the opening size given.
2. Approximate shipping weight is 5.0 lbs./sq.ft.

LOUVER SIZES

Min Panel	Max Single Panel
12"W x 12"H	48"W x 96"H

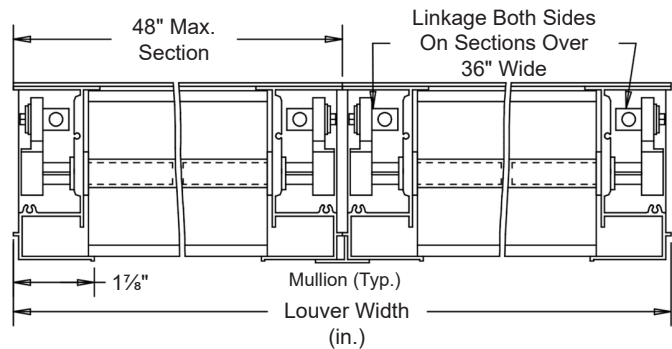
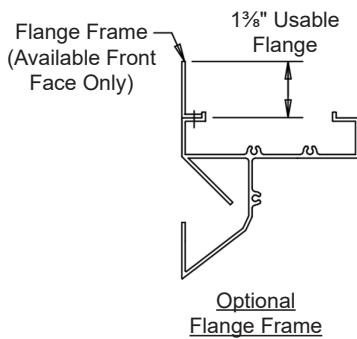

Item #	Qty	Width	Height	Width	Height	Mullion	Type	Location	Union Made
		Opening Size		Louver Size			Screens		
Arch. / Eng. :						EDR:		ECN:	Job:
Contractor:									
Project:						Date:		DWN:	DWG:

In the interest of product development, Louvers & Dampers reserves the right to make changes without notice.

www.louvers-dampers.com

450 Riverside Drive • Wyalusing PA, 18853 • Phone 570-746-1888 • Fax 570-746-9286



PERFORMANCE DATA

Pressure Drop: .16 in. w.g. at 1000 fpm (intake)
 Free Area: 6.84 sq.ft. = 43% for 48"W x 48"H sample tested in accordance with AMCA Standard 500-L.
 Beginning Point of Water Penetration: 1044 fpm

Ratings do not include the effects of a screen

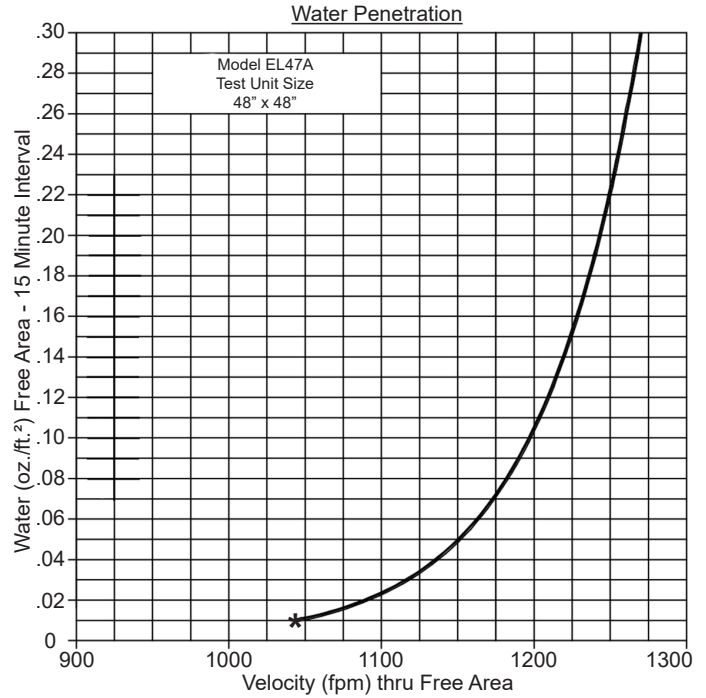
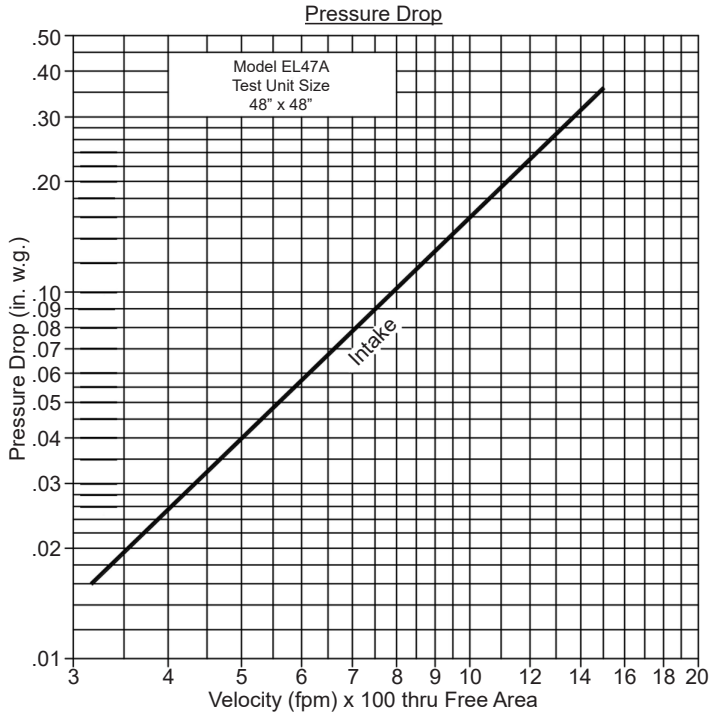

1044 (FPM) Beginning Point of Water Penetration.

Intake air converted to standard air density.
 Tested to AMCA Standard 500-L, Figure 5.5.

		Free Area (sq.ft)						
		Width (in.)						
		12"	18"	24"	30"	36"	42"	48"
Height (in.)	12"	.15	.27	.39	.50	.62	.74	.85
	24"	.50	.88	1.26	1.63	2.01	2.39	2.77
	36"	.85	1.49	2.13	2.77	3.40	4.04	4.68
	48"	1.20	2.10	3.00	3.90	4.80	5.70	6.84
	60"	1.55	2.71	3.87	5.03	6.19	7.35	8.51
	72"	1.90	3.32	4.47	6.16	7.58	9.00	10.43
	84"	2.24	3.93	5.61	7.29	8.98	10.66	12.34
	96"	2.59	4.54	6.48	8.42	10.37	12.31	14.26